

"EASY-BUILD" CRAVENS CLASS 105 DMU ASSEMBLY INSTRUCTIONS.

PLEASE READ THESE INSTRUCTIONS FULLY BEFORE PROCEEDING WITH ASSEMBLY AS MORE THAN ONE ORDER OF CONSTRUCTION MAY BE USED. SAFETY FIRST! CONSTRUCTION REQUIRES THE USE OF VOLATILE SOLVENTS, ALWAYS FOLLOW THE MANUFACTURERS INSTRUCTIONS AND ENSURE ADEQUATE VENTILATION. YOU WILL ALSO REQUIRE SHARP TOOLS AND THE EDGES OF THE ETCHED PARTS CAN BE VERY SHARP SO TAKE CARE WHEN HANDLING. WORK STEADILY AND SAFELY AT ALL TIMES.

INTRODUCTION

The general idea for assembly is to construct a box with a removable floor. In order to get the most from your kit we recommend you read these instructions in full prior to commencing construction making notes as to any assembly options, or changes to the suggested order you think would suit your method of building better. However, we suggest you do follow to the order of construction as we know it works! Photo references will be found throughout these instructions and consist of images of both these units and relevant pictures of our class 129.

GETTING STARTED

The basic steps are the same for both car types, so unless there is an operation specific to a particular body type the instructions should be applied to both units as required. Wash all moulded parts to remove moulding and machining lubricants.

PREPARING THE SIDES

1) (Both Cars) Check each side moulding against the edge of the end mouldings. Whilst we take great care to ensure the ends of the side moulding are true and square, take a few moments to check that the ends will make a good joint with the sides. Also, remove a small amount of the moulded rib on the inside of each side at the non-cab ends, i.e. the baggage end of the DMBS and the toilet end of the DTCL - about 3mm is ample. Also check all window openings for cutting burrs and remove as necessary.

2) (DMBS) The power car have guard's doors that, on the prototype, open inward. To help you identify the sides they are marked inside 1DMBS and 2DMBS in marker-pen. The guard's compartment is located in the baggage area, so the guard's door is one of the double (baggage) doors with a window on each side. On the 1DMBS that is the first windowed door at the right hand end; on 2DMBS the first windowed door at the left hand end (as you look at the side flat on the table), see right. To depict the guard's doors simply remove the bottom edge of the relevant doors. As a guide remove the bottom of the door up to the bottom of the moulded ridge on the inside of the body. Ensure you cut squarely inside the door scribe-line and that

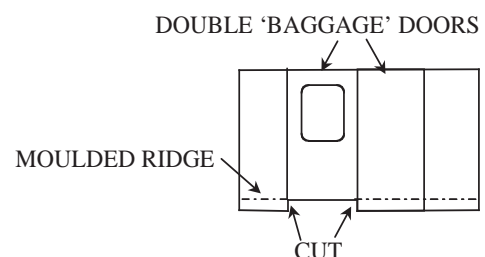

the bottom of the door is finished horizontal.

3) (Both Cars) With the exception of the guard's compartment, all doors have externally fitted hinges. Drill through all the holes in the sides 0.7mm dia. for door hinges, handles and door bump-stops (see step 10 before continuing).

4) (DMBS) Guard's doors also have vertical handrails either side of the door, these too need holes drilling through 0.7mm dia. There are no location marks (on first batch of kits - we forgot!) so carefully mark and drill their mounting holes (measured from the bottom of the body side) at 3, 10, 13 and 35 mm at 1mm either side of the door scribe marks.

5) (Both Cars) Check the fit of the sides against the cab ends - make sure you've got the correct end of the side to work with, i.e. the non-baggage, and non-toilet ends. The sides should be level with the bottom edge of the cab. It is necessary to create a small rebate (about 5.5mm long x 1mm deep) at the top edge where the sides meet the underside of the roof. The upper edge of the end, where the roof meets the edge of the door opening is slightly angled (a production process aid) and will also need to be filed square in order to accurately create the rebate in the sides. This last step is mentioned again in the End Prep section.

***TIP- Number the ends and sides on the inner surfaces to ensure each side mates with it's appropriate end later on.*

6) (Both Cars) Check the depth of score lines at the door positions and deepen if you prefer. Carefully remove the raised burr from the door opening scores, work slowly and re-open score marks as necessary until desired effect has been achieved.

***TIP - Use a gentle scraping action followed by 1200 wet-n-dry (wet is best) for these two operations. Alternatively, a small chisel can be used to shave off the burrs. Old flat needle files can be ground into chisels and are ideal for this purpose. Be careful not to dig into the surrounding surface of the sides.*

7) (Both Cars) There are filler tank recesses on each vehicle side, carefully open these out to form oval holes - do not stray outside the machined outline. Once satisfied with the size and shape carefully file the bottom of the opening flat - do not lengthen the opening during the process. Whilst working here, remove a section (about 7mm) of the inner body rib in line with the fuel fillers. This is necessary to allow the filler castings to be located properly. Fit the copper rivet into casting C10 to represent the filler cap then attach at the rear of the cut out. Don't forget that the sides have curved profile so some light filing may be required to get a snug fit (see Filler back casting.jpeg and Filler casting in place.jpeg).

8) (Both Cars) Now would be a good time to give the sides a rub down with 1200 grit wet & dry to really see what the final job looks like. At this stage you can go over any of the previous body prep. operations quite easily until you are fully satisfied with the results. Once the door hinges are in place it is much more difficult to do so.

9) (Both Cars) Initially you will need 12 sets of hinges (2 large and 1 short hinge per door). Remember that the short hinge goes in the centre with a large hinge top and bottom. Remove an equal number of 'butterflies' from the etch, 1 for each hinge. The hinge piece is pushed through a butterfly shaped backing piece then glued into the hole in the side trapping the butterfly with the hinge. Remember - the guard's doors open inward so have no visible external hinges.

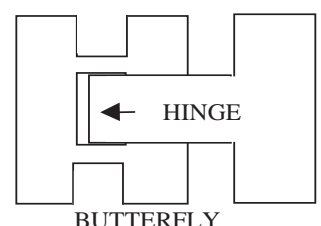

***TIP - You will find that the application nozzle on many brands of superglue will fit neatly over the hinge's spike. Once pushed through the body side push the nozzle over the protruding spike and gently squeeze a small amount of glue into the hole.*

10) (Both Cars) Using the 1mm micro rod 'plug' the holes in the door centres and those to the left (and right for baggage doors) of the doors to represent the doorstops. Note, when drilling the holes the size stated for the door bump-stops was 0.7mm, this enables other solutions to be considered for this detail. If you do use the micro rod open out the holes accordingly. The stops should be trimmed so that they protrude not more than 1mm from the sides. Note: doorstops are not fitted to all doors (e.g. none on the guard's doors because they open inward). Do not fit door handles and grab irons until after painting.

11) (Both Cars) Some cars had blanking panels immediately behind the cab doors. They are now supplied on the CI. 105 Extras etching parts E21 & E22. Part E21 goes on the driver's side with the cut-out around the grab handle. Fix the panels centered vertically compared to the adjacent window and centrally between the door openings and first window using superglue, some slight curving of the etching will produce a better fit against the body profile. We know these panels were fitted to most of the units operating in East Anglia, but other areas probably had them too, check photographs to be sure.

That completes the sides for now.

ROOF PREP

You will notice your roof has a curve due to the moulding process this is useful when fitted as it ensures the roof is a tight fit in the centre of your coach.

12) (Both Cars) Clean off any burrs of plastic then put a strip of masking tape down the centre of the roof onto which you can mark the positions of roof vents etc. from the drawing provided (Drawing 2). Notice that one end of each roof is cut square whilst the other is shaped. The shaped end is the non-cab end (rear) and all measurements are taken from that end at the longest point, i.e. along the centerline.

13) (Both Cars) Drill 2mm dia. mounting holes for the roof vents at the locations marked and a 1.3mm hole for the water filler casting (DTCL only).

14) (Both Cars) Remove a small amount of material (about 5mm in length) from the inner edge of the underside of both side locating channels at the shaped end of each roof (see right). This allows the roof to sit down over the end moulding. **DO NOT REMOVE THE OUTER PART OF THE CHANNEL AS THIS FORMS THE ROOF RAINSTRIP. SEE [Inner roof channel mod.jpeg](#).**

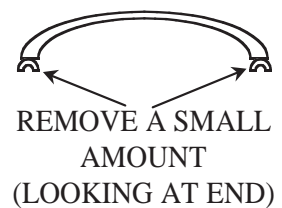

Although you can fit the roof details now, leaving them until later can make the blending of the roof section to the cab roof easier.

FLOOR PREP

15) (DTCL) During the construction of the demo model, it came to light that the floor of the trailer car should have been marked to determine its front and rear. (We found out the hard way by building the demo model floor backwards!) Mark the FRONT of the DTCL floor as that with the bogie pivot CLOSEST to the end of the floor moulding. The power car does not need marking because the motor cut-out in the floor makes orientation obvious.

16) (Both Cars) Check the floor moulding for flatness - if it appears too distorted (some curvature is quite normal) gently bend it in the reverse direction to correct.

17) (Both Cars) It is likely that you will have to adjust the floor width to gain the best fit inside the body. This is not necessary on our coaches because the floor and sides form a solid box, for this application it is better to have the floor removable. Reduce the floor width by about 1.5 mm by carefully shaving off small amounts evenly from each side to keep the floor central to the body. This is best done using a scraping action with a sharp blade. This operation may need to be repeated when the body and underframe are assembled for the first time.

18) (Both Cars) Locate the two aluminium bogie mounting turnings and prepare them by scoring their upper surface (the spigot faces downward when in use see right). Treat the mounting areas likewise. Using a strong adhesive fix the two round turned bogie mounts in the holes in the floor.

***TIP - Bogies present quite a load to their mountings mainly due to the ease by which they get knocked and twisted when the model is off the tracks, it is therefore necessary to select an adhesive capable of withstanding such shocks. Two part epoxy resins are more suitable than superglues.*

19) (Both Cars Optional) It is highly recommended that to make a much stronger job of fixing the bogie pivots in place, you might consider a 'belt and braces' approach by adding a mechanical fixing to the mounting. Good results have been achieved by drilling two 1mm holes through the bogie mountings and floor (once the mounting has been fixed in place) either side of the bogie pivot bolt and tap 12BA. Now secure the bogie pivot in place by bolting down through the coach floor with short 12BA bolts (see bogie mounting diagram, above).

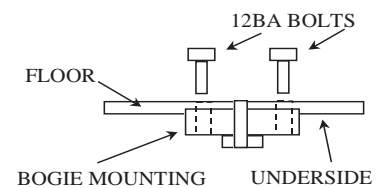

CAB ENDS PREP

20) (Both Cars) Ensure the corners under the roof at the door top positions are filed square and remove any moulding flash from window openings, etc.

21) (Both Cars) Remove the right hand moulded grille from the cab front. Use a small file and finish with fine abrasive paper.

22) (Both Cars) Drill two 0.4mm dia. holes in the centre of each window directly above the upper window beading to mount the windscreen wipers later (see **Craven end 2.jpeg**).

Prototype photographs reveal that not all units carried windscreen wipers on both windows. Some are shown with a single wiper on the driver's side (fortunately!), whether that was common, or not is unclear as is when the practice began, but you might wish to fit just a single wiper and thus only need to drill a single hole above the right hand windscreen.

23) (Both Cars) The small destination board E15 (use those on the Cl. 105 Extras etc) should now be fixed to the front of the cab. Having carefully removed it from the fret and trimmed the tabs position it centrally on the cab rainstrip and mark the extremities of the angled tabs. Carefully remove the rainstrip between the two marks, filing and sanding as necessary. Fix the destination board in place using superglue with the two angled tabs angled downward, the bottom of the tabs should be aligned with the bottom of the adjacent rainstrip (right). See **Cab destination board1.jpeg** and **Cab destination board2.jpeg**.

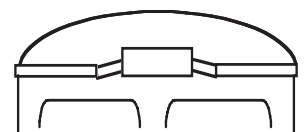

24) (Both Cars) Cut from scrap styrene 4 desk mountings as shown here (right), fix to the floor of the cab against the cab front with the tallest side forward. See **Craven inside cab.jpeg** for example.

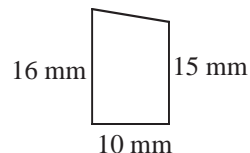

25) (Both Cars) Cut glazing to fit the windscreens now as this is very difficult to do once the body has been assembled. Start with pieces 20.5mm x 23.5mm and then round the corners sufficiently to clear the moulded inside corners of the glazing recess inside the cab. DO NOT FIT just keep safe for now.

If you intend to illuminate the end lights these should now be drilled out as required. No provision is made for this in the kit and so it is up to the builder to determine how best to achieve the installation.

NON-CAB ENDS PREP

26) (Both Cars) These are our standard BR Mk1 coach ends and so have some details not required on a these units. Remove all the moulded on details with the exception of the water filler pipe retainers on the end to be used on the DTCL. These operations are best achieved by shaving small amounts off with a sharp blade, followed by a fine file and finally fine abrasive paper. See **End prep.jpeg** (Note on our demo model we left on the emergency brake details which should also have been removed).

27) (DMBS) If you plan to model your brake compartment with end windows these need to be carefully opened and filed to shape. Follow the half milled profile inside the moulding - this should be done only after the step mounting pads have been removed as noted above.

28) (Both Cars) With a fine razor saw, cut off the moulded on bufferbeam level with the bottom of the end. Use the underside of the end as a fence to guide the saw blade and finish off with a flat file to remove any burrs.

29) (Both Cars) Give the ends a final inspection and rub over with fine abrasive paper before moving on.

BODY ASSEMBLY - NOW FOR THE FUN PART!

Whilst the solvents used to assemble the components evaporate very quickly the joints they produce take considerably longer to achieve maximum strength. DO NOT RUSH THESE NEXT STEPS. Leaving ample time for the joints to harden is essential and you will be rewarded for your patience by not having unsound joints later on.

30) (DMBS) Fix a cab end to one side at the opposite end to the baggage compartment and the non-cab end to the other side adjacent to the baggage compartment to form an 'L' shape half box as shown below right.

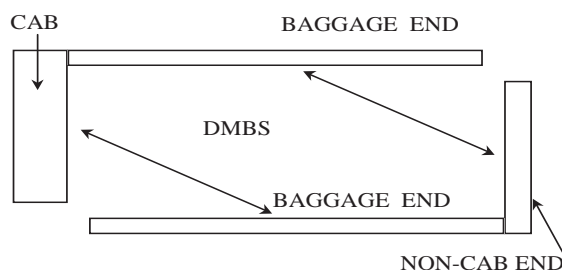

31) (DTCL) Fix a cab end to one side at the opposite end to toilet compartment (with the two small end windows) and the non-cab end to the other side adjacent to the toilet compartment to form an 'L' shape half box as shown right.

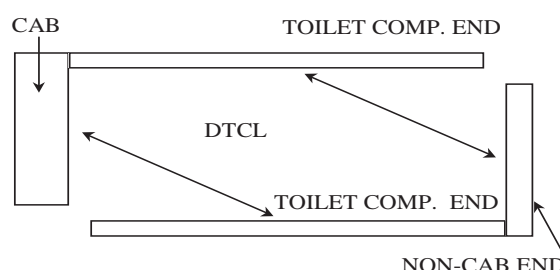

Assuming care was taken when preparing the ends and sides your sides will be level at the bottom. Ensure the outside faces of the sides are a good match, in profile, to the outside of the ends at the door line. Allow the ends to harden before attempting the next step.

***TIP - Working on a glass sheet will aid accurate bottom alignment of the sides and ends.*

32) Assemble the two half boxes again using a flat surface to aid alignment. The box may twist a little to during this process due to the flexible nature of the materials, but do not worry unduly as the roof will bring everything back in line later.

LEAVE TO SET HARD AND BUILD THE BOGIES (BOTH CARS)

The instructions here initially refer to an un-powered bogie. Note also that the bogie spues contain parts that are not intended for the DMU so please refer to the illustrations to identify the appropriate parts to use.

33.1) Remove three bogie frame stretcher plates from the casting sprues and cut off the ends level with the inside edge of the moulded angle (see right). Clean up and square off as necessary.

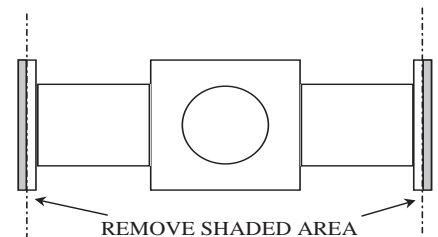

33.2) Push brass bearings into the axle holes making sure they are an easy sliding fit, but not sloppy - if necessary clean hole with a 2.5mm drill. Do not fix in position as adjustments will be made later.

33.3) Using a pin, add a tiny drop of oil, NOT WD 40, into the bearing surface.

33.4) Place two non-driving axles in the bearings of one side frame and, ensuring correct orientation of bogie frame stretcher plate (reinforcing cross members down), assemble the side frame to the frame stretcher.

33.5) Once the first frame is reasonably firm, assemble second side frame onto frame stretcher in the same manner. When the side frames are secure enough to hold themselves in place, make certain all is square and in line, minor adjustments can still be made at this stage by applying more solvent to soften the joints and adjusting as required. Note: wheels should be a loose fit in the bearings at this stage. Leave the bogie to set for at least 1 hour, 2 is better.

With the joints set hard you can now set the axle bearings:

33.6) Centralise the wheelset and insert a thin piece of card between each wheel and the side frame to prevent lateral movement.

NOTE: Do not over-pack the wheelsets as this might cause the sides to spring when you remove the card later resulting in stiff wheel movement.

33.7) Push in the bearings from the outside until the bearings connect with the axle ends.

33.8) When satisfied that the bearings are (just) against the pinpoint ends fill the bearing hole with the 2.5mm sprue supplied, or microrod (not supplied) and fix with liquid solvent from the outside and leave to harden.

33.9) When set, remove spacing card and trim any excess rod flush with axle box face

33.10) Remove the bogie pivot mounting from the casting spue and remove any flash. Test the bogie pivot bolt is an easy sliding fit in the mounting hole. If tight, open the slightly with a 3.5mm drill to ensure a smooth swivel movement.

33.11) Drop the bogie pivot mounting into its locating holes in the top of the bogie stretcher plate and, using only sufficient glue to attach the plates, fit keeper plates over pivot spindles. Ensure pivot remains free to move until the liquid solvent has evaporated.

You may prefer to use a larger piece of sheet styrene (not supplied) rather than the moulded keeper plates supplied.

33.12) If desired, fit the brake shoes on the inside of the sideframe. They should be positioned just off the wheels with the circle detail on the shoe just visible below the bottom of the side frame.

33.13) Fit the bolster detail centrally to the inside of the sideframe by placing the square beam against the back of the sideframe and butt against the underside of the bogie stretcher.

While the basic bogie assembly sets, identify and remove the bogie front channel, guard irons, speedo drive mount and bogie steps from the etched sheet.

33.14) Fold up the bogie channels E3 (plain) & E3a (with slots for guard irons).

33.15) Locate the guard irons (E7) in the channel with the top of the guard iron firmly against the top of the channel section and passing through the slots and solder in place. See **Bogie end channel 1.jpeg** for clear view of channel. Note that only the front bogie, i.e. the cab end, has guard irons fitted.

33.16) Remove the dynamo mounting bracket (E17) from the etch, fold to form a U and solder centrally into one of the channels. Close the legs sufficiently to meet the mounting lugs on the dynamo and solder in place (see **Dynamo mounting.jpeg**)

33.17) Glue the bogie channels to the front and rear of each bogie with the bottom of the channel level with the bottom of the sideframe (superglue is recommended for this). The arrangement of these channels should be:

DTCL & DMBS Front bogie: guard irons and plain channel

DTCL Rear: dynamo assembly and plain channel

DMBS Rear (powered): plain channels front and rear

See also **Bogie end channel in place.jpeg**

33.18) Fold up the bogie step tread supports and mounting brackets (E2). See **Bogie step and speedo drive.jpeg**

33.19) Glue the speedo drive mounting (E14) to the front left axlebox having first reduced the 'peg' to a tapered spike. The spike faces right and down when fitted in place.

33.20) Glue the bogie step mountings in place. The front mounting is in line with the front spring hanger and the bottom step tread should be (approximately) level with the large spring mounting bobbin. Ensure the step is kept parallel to the side frame and attach the rear mounting to the top of the side frame. See **Bogie step and speedo drive.jpeg**.

***TIP Flattening the front spring hanger 'bobbin' back to the level of the leaf spring greatly simplifies the fitting of the step mountings. Although un-prototypical, once painted the flatness is hardly noticeable.*

POWER BOGIE

34.1) Find the brass (painted black) power-bogie stretcher-plate and the two sets of wheels with sprockets and drive gears fitted.

- 34.2) Fit axle bearings into the two remaining bogie sideframes.
- 34.3) Push the two moulded pins of one sideframe through the holes in the stretcher plate (with the folded sides hanging down) and glue into place.
- 34.4) Insert the wheelsets into the sideframes ensuring the set with the brass gearwheel is at the same end as the motor mounting and that the sprockets are on the same side.
- 34.5) Fit the opposite sideframe as before and glue in place.
- 34.6) Finish off detailing the bogie assembly as outlined for DTCL (rear) except for the dynamo, but not forgetting the central bolster detail.
- 34.7) Fit the motor to the frame stretcher and glue the pick-ups to the stretcher underside ensuring the wipers have a good contact with the backs of the wheels.
- 34.8) Align the worm wheel with the gear and clip the drive chain in place.
- 34.9) Lightly lubricate all moving parts and test.
- 34.10) There are two different types of axlebox covers supplied in the kit, use the slightly domed Timken covers for the Cravens unit. Fit covers to all remaining axle boxes (see Bogie speedo drive.jpeg).
- 34.11) Cut 8 15mm x 5mm x 0.7mm (30 thou) step treads and fix to the step supports of the front bogies of both units.

BODY ASSEMBLY CONTINUED...

OK, the sides and ends will now be firmly fixed so will withstand the handling necessary to fit the roof.

35) (Both Cars) Fit the floor fixing captive nuts into the moulded channel on the underside of the roof. Slightly reducing of the width of the captive nuts will make their fitment easier, however don't overdo it as you don't want them sliding about when trying to screw the floor in place, nor have them dropping out! A third captive nut is included as an alternative method of preventing the floor from sagging in the middle once all the underframe castings are in place, see **step 55** before proceeding and decide which method you wish to adopt.

NOTE: BEFORE PROCEEDING MAKE SURE YOU HAVE GOT THE CORRECT ROOF AND BODY PAIRED TOGETHER. DMBS AND THE ROOF WITH THE EXHAUST; DTCL AND THE ROOF WITH THE WATER FILLER.

36) (Both Cars) Assuming everything has been assembled accurately the roof should fit neatly against the cab moulding at the front with the rear overhanging the end. When the roof is in place the top of the sides will locate in the groove under the rainstrip. You may find the central moulded channel on the underside of the roof needs trimming back to enable to roof to fit between the cab and the rear end moulding. Fix the roof in place by initially applying solvent from the inside along the joint of the cab/roof moulding then along the joint between the roof and the side mouldings, again from the inside. Be very generous with the solvent here as the ABS can be reluctant to soften.

37) (Both Cars) To make a very secure job, reinforce the sides/roof joint with 30thou (0.7mm) micro rod again with liberal amounts of solvent. This method can also be applied to the non-cab ends to great effect.

LEAVE BODY TO HARDEN

38) (Both Cars) Once the roof has firmly set, take time now to inspect the fit of the roof outline against the end moulding. Due to the different means by which the roof and ends are produced, it will

be found that the alignment of the roof line and the ends requires some blending with an appropriate car body, or modelling filler. Likewise, there is a gap between the underside of the roof and the top of the non-cab ends which will require filling as necessary.

Once again, do take your time with these steps not least because the roof and end joints will be very visible on the finished model.

39) If the roof vents and exhaust pipes were not fitted earlier now is the time to do so. The roof vents will also offer the body some extra stability when it is placed upside-down for the following steps.

40) (DTCL) form and fit the water pipes to the filler casting (C35) on the roof and down to the brackets moulded onto the end. Use 0.7mm brass wire for the pipes, file the ends of the two halves flat, solder together, drill a hole through the body of the filler and insert the pipe end. The pipes roughly follow the profile of the coach end and pass through the moulded pipe retainers. Cut off the pipes about 2.5mm below the retainers.

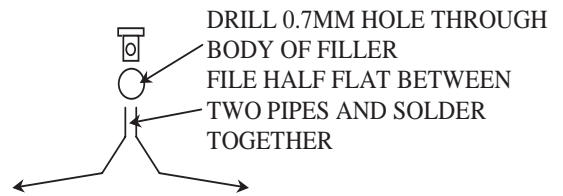

UNDERFLOOR ASSEMBLY

41) (Both Cars) First check the floors will fit within the sides and end mouldings. It is likely that you will have to adjust the floor width to gain the best fit. Do this carefully removing the minimum amount evenly from each side to keep the floor central to the body. This is best done using a scraping action with a sharp blade.

42) (Both Cars) Locate the two spues containing the roof vents and bufferbeam on which you will find two other 'odd-shaped' end fillet pieces. Remove these pieces, clean as necessary and fix 2 to the edge of the solebars at the front of the floor mouldings as shown right.



***TIP - it may be prudent to back the end fillet with scrap styrene to improve its robustness as shown dotted in the diagram.*

43) (Both Cars) Remove the bufferbeams from their sprues, clean flash, etc. and check the fit of the buffer shanks into the holes. Use a drill bit to carefully open any tight holes to allow the buffers to slide easily. Fold the etched lamp brackets E12 to form a 'joggle' shape (right). The etched lamp iron mountings are fitted on the four 'lugs' moulded around the buffer shank holes, the buffer stocks are then glued onto the brass backing.

***TIP: Use the drill bit shank as a aid to align the three parts of the buffer assembly taking care not to glue the drill bit into the buffer hole! See 3 images Buffer Assembly (1, 2, 3).jpeg.*

44) (Both Cars) Install the floor moulding into the body and temporarily secure into position with the supplied bolts. Now fit the bufferbeams to the underside of the cab ends, aligned centrally across the cab and butted against the end fillets to ensure vertical squareness. **DO NOT GLUE THE BUFFERBEAM TO THE END FILLETS BECAUSE IF YOU DO, YOU WILL NOT BE ABLE TO REMOVE THE FLOOR AGAIN!**

***TIP - Adding fillets of scrap styrene between the underside of the cab and the bufferbeam will greatly increase the security of the assembly. Aligning the fillets with the underframe ribs will ensure*

they will not interfere with fitting other details, or the couplings later.

45) (Both Cars) The rear bufferbeams should be fitted directly to the floor moulding. Take care as it is quite difficult to achieve this without also gluing the floor to the end of the body. Initially tack the bufferbeam in place then remove the floor from the body and finish off the job, reinforcing the joint as appropriate.

46) (Both Cars) You may wish to leave the bufferbeam details until later as they are quite vulnerable. However at the cab end are vac pipes (casting C8) which emerge from the bufferbeam at approximately buffer centre height and about 6mm either side of the coupling hook. The air horns (castings C2) go to the driver's side and just inside the floor front fillet piece.

The floor moulding can now be removed from the body and the remaining details fitted to the body and underframe.

ADDING THE REMAINING BODY DETAILS

47) (Both Cars) Now would be a good time to assemble the control desk details as per the diagram and check for fit inside the cab. The brake wheel is now an etching, solder a 14BA cheesehead bolt into the central hole to mount the wheel into the desk.

48) (Both Cars) On the driver's side of the cab you will need to drill three 0.7mm dia. holes through the seam between the cab end and the body side moulding. These should be positioned to align with the other door hinges (approx. 4mm, 20mm and 28.5mm as measured from the bottom of the body). Also, drill holes for the grab handles at 15mm and 20mm. and short handrail (blue livery only) at 3mm and 10mm - all 1mm from the right hand edge of the door. The short handrails, if required can now be fitted, but the grab handles should be left until after painting.

***Note - Door hinges are always on the left of the door as you look at them.*

See Drawing 1 for layout of the interior of the two cars including the partitions as described in the following steps.

49) (Both Cars) Carefully remove the cab partitions E6 from the fret. There is a fault with the design in that the door outline should only be a half etch, but as you can see it is etched through. You may wish to correct the error by filling the gap with solder before continuing. Alternatively simply adding a short piece of 0.5mm wire across the top of the etch will secure the top of the door, once painted the gap is not too noticeable from normal viewing positions. See **Cab partition prep.jpeg**

50) (Both Cars) Fold the bottom of the partition along the half etch. Check the width of the cab partitions inside your body and trim as necessary to achieve a sensible fit. The partition should be able to sit between the moulded ribs at the base of the body sides.

51) (Both Cars) From scrap styrene cut two cab floors 14mm x 57mm (approx) and fit to the folded base of the cab partitions to form a cab floor. Fit into position adjusting the various items as appropriate. Add scrap styrene to the inner body sides to offer some additional support to the upper part of the partition (do not obstruct the window openings and remember the glazing will need to be fitted later). Clean and fit the cab seat (casting C10) to this short cab floor positioned to roughly align with the curved recess in the cab desk and its back just clear of the partition.

52) (Both Cars) You will also need two more partitions with doors (E6) preparing as above, but without the styrene floor. These will be fitted at the first passenger door to form an enclosed saloon

behind the driver's cab the remaining partitions are open with handrails. See also the note regarding the removal of the wedge (53.4).

53.1) (Both Cars) Also inside the body are the saloon partitions E16, you will need 5 preparing as follows:

53.2) Remove from fret and bend the bottoms 90° along the half etched line.

53.3) Add a vertical handrail between the notch at the top and the partition lower wall using 0.9mm brass wire. You might also find handling the partitions easier if you add a short length of wire brace across the opening at floor level.

53.4) (Both Cars) Something we'd not realised when designing these parts was that they would need to be able pass by the fuel filler castings glued to the inside of the body. In order for this to be achieved remove a 'wedge' section from the lower part of the partitions just sufficient to allow the partition to be fitted into place (see diagram). Also carefully trim the edges to allow the partition to fit between the body sides, We've made the internal opening in these parts a bit too wide so this trimming is a bit tricky. However, they can be trimmed and fitted in one piece.

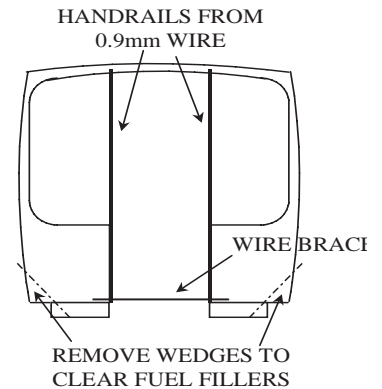

54) (DMBS) The final partition is created from the moulded ABS divider. This will need trimming as necessary to fit immediately behind the last passenger door. Once prepared this partition can be permanently glued into position.

55) (Both Cars) Cut four pieces of 60 thou (1.5mm) styrene 18mm wide to fit between the body sides immediately above the moulded rib (they should be about 58mm). Fix inside the body on top of the moulded rib and aligned centrally with the passenger doors. These will be used later to mount the partitions in place. These internal stretchers can also be used later to provide additional support to the underfloor (which can sag under the weight of the metal castings) by drilling through the floor and stretcher and securing together with a self tapping screw. See **mid body strengthener and cab walls.jpeg** for this additional support as used on the Class 129.

That just about covers the body detailing at this stage. Glazing and the etched security bars are left until the unit is painted.

UNDERFRAME DETAILS

Before commencing detailing the underframes please familiarise yourself with the underframe detail castings for both cars. Looking at the images of the supplied castings for the two cars you will notice that there are 'gaps' in the numbering system. The reason for the gaps is because some castings are used on both cars and others only used on a single car. The castings for each car are to be found in the relevant box so take care not confuse which parts go on which car. To further help in identifying the parts correctly drawings of the two underframes are also labelled with the appropriate numbers together with a part description. The castings offer a considerable amount of load to be held upside down so strong adhesives are required. We have tried Evostick on recent models with very good results.

DTCL UNDERFRAME

Refer to the DTCL drawing for component spacing measurements. In addition to the pewter castings, you will also need the brass brake hanger and lever details and some 1mm soft wire. Before assembling clean any flash from all the components. See DTCL Drivers side.jpeg and

Second man side.jpeg.

56.1) Temporarily place the underframe into the body and mark the solebars to show where the doors are (both right and left hand edges of the openings) - remove floor.

56.2) With the front of the underframe pointing right and upside down, the solebar nearest to you is the driver's side of the car. Working left to right on this (the driver's) side fix castings: 1 each C12, C13, C14, C16 to the floor. The space heaters C12 and their filter brackets can be pre-assembled before the sub-assemblies are fitted to the floor.

56.3) Assemble the brake hangers E18 (x2), brake shaft and levers E19 (x2), E20 (x2) using a 27mm length of 1.5mm brass for the shaft. The small brake levers E20 are used for the pull rod to the bogie, so position them on the brake shaft along the floor centerline, but hanging down towards the rails. If required use some 0.7mm rod to simulate the actual bogie pull rod. The brake cylinder C17 should be located so that the pull-rod coincides with the lever mounted on the brake shaft. The pull-rod is made from a short length of 1mm brass rod.

56.4) On the other (second man's) side fix (in order) 1x C13, C7, C19, C16, C12, C14 again following the dimensions in the DTCL diagram. There is also a second C13 on this side, however this one is fitted with the rebate facing inward as it is only used to provide a mounting for other castings. The rebate should be placed over the first inner rib - you will need to file a little material from the underside of the casting to allow it to clear the small step adjacent to the inner rib and sit flat to the floor.

56.5) Fit the speedo drive backing E13 and casting C3 to the driver's side solebar about 37mm from the front of the floor.

56.6) Now fix C1 & C9 to the fuel tank and add conduits from 1mm soft wire and the relay boxes C15 to the back-to-front fuel tank. The fronts of all these detail castings should be set back slightly from the inner edge of the the solebar.

56.7) Fix the fuel gauges E11 and blanking plates E10 to the front (angled) faces of the fuel tanks, approximately 3mm from each end. The fuel gauge goes to the end of the tank nearest the bogie on both tanks.

DMBS UNDERFRAME

57.1) Temporarily place the underframe into the body and mark the solebars to show where the doors are (both right and left hand edges of the openings) - remove floor.

Once again working with the front pointing to the right and with the underframe upside-down the solebar nearest to you is the driver's side of the car. See DMBS Drivers side.jpeg and DMBS Second Man side.jpeg.

57.2) Fix the two battery boxes C29 on top of a pair of fuel tanks C13, about 2mm back from the edge of the angled face.

57.1) Add the two etched grills E8 to the rectangular opening of the two radiator blocks C27.

57.2) Assemble both space heaters C12 and their filter brackets C14.

57.3) Fold up mounting bracket E9 and affix 2x C21 and C24.

57.4) Assemble the two diesel engines C26 by attaching C20 as shown right. Also attach C23 and the oil filler pipe (not illustrated on the castings picture).

57.5) Starting on the driver's side (rear) fix a fuel tank with battery box

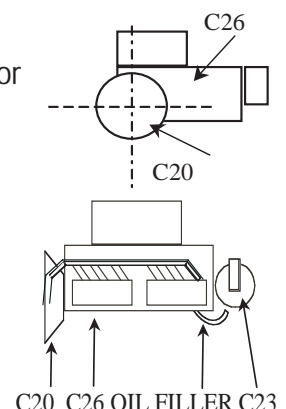

(C13/29), space heater (C12/14), radiator (C27), diesel engine (C20/23/26) and finally a second fuel tank C13 (without any fittings attached). The diesel engine mounts between the two central underfloor ribs.

57.6) Fix the remaining details in place on the driver's side following the DMBS driver's side drawing (the upper drawing).

57.7) On the other (second man's) side fix a fuel tank C13 (without any details added), diesel engine (C20/23/26), radiator (C27), space heater (C12/4) and fuel tank with battery box (C13/29).

57.8) Fix the remaining details as shown on DMBS lower drawing. Also add fuel gauges and blanking plates to the fuel tanks, these again sit about 3mm in from each end of the fuel tank with the gauge to the outer edge of the tank, i.e. nearest the bogie.

57.9) Probably the trickiest part is creating the exhaust pipes. Annealed 1.5mm copper wire was used on the demo models. Both exhaust pipes travel towards the guard's compartment and then pass up through the floor. The point of entry into the floor is approximately 115mm from the rear of the floor. Aim for the gap between the fuel tank and the moulded rib for the entry point. Once the pipes have been formed, carefully solder to the exhaust pipe stub cast onto the diesel engine and glue the other end to the floor.

57.10) Fit the speedo drive backing E13 and casting C3 to the driver's side solebar about 37mm from the front of the floor.

58) (Both Cars) Cut 12 off 20mm x 5mm, 2 off 30mm x 5mm of 0.7mm (30 thou) styrene as step treads. Due to the position of the fuel tanks, it is not possible to use our usual step supports located behind the solebars. The steps therefore have to be self supporting on the edge of the solebar. Use the 20mm steps for the passenger and cab doors and the 30mm steps for the baggage/guard's door. The steps should be aligned with the previously made marks and level with the bottom of the solebar. Additional strength can be gained by adding a strip of styrene to the front of the solebar in line with the step, once painted it is hardly noticeable.

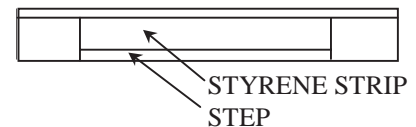

***TIP - The outer edges of the steps should not be left too square cut, i.e. round off the upper edges and slightly round the corners. The steps were made of wood and soon became worn.*

FINISHING

59) (Both Cars) With the main construction now complete it is time to prepare the model for painting. Whilst this consists of mainly cleaning and washing of all the parts, it also gives you another opportunity to check the security of the various fittings. Anything that cannot stand cleaning will probably not withstand long-term use, so it's better to have bits falling off now than later - refit as required!

Painting is not a subject to be condensed into a few lines, so we will assume that you already have the means to produce the required livery (if not we can help). Liveries carried were green with speed whiskers and dark grey roof (as built); green and small yellow front warning panel and finally corporate blue with full yellow ends. We recommend the excellent transfers supplied by Fox. The only item we must mention is that concerning the side windows. The window bars will need painting in the main body colour prior to fitting the windows. Also, don't forget to paint the etched window security bars for the baggage area which can be painted whilst still on the remaining frets.

***TIP - To improve colour intensity of the glazing bars (bearing in mind the plastic is clear) apply a*

thin coat of grey primer, followed by a thin coat of black and finally thin coats of body colour.

INTERNAL DETAILS (BOTH CARS)

SEATING

60.1) Prepare the coach seats by removing the ejection pin marks (small round marks on seat back) and moulding feed joints.

60.2) To form the seat, flex the moulding until the joint between the base and seat back shows a thin white line. Gently score along the white line (not too deeply) from the rear of the seat with a craft knife and fold up the back towards the base. Apply solvent to the joint holding together briefly to prevent the back from initially springing apart.

60.3) The arm rests can be added to create first class type seats if required.

60.4) On the rear of the twin seats you will find a pair of ashtrays, on 8 seats remove the right hand ashtray and on a further 8 seats remove the right ashtray. These handed seats are used where the seat has an occupant sitting behind and able to use the ashtray, but the ashtray is only on the non-aisle side of the pair. All other twin seats can have both ashtrays removed (if you wish).

60.5) When painting the seats the ashtrays were chromium plated and there was a chromium plated bar across the top of the seat back, both of which can be depicted with silver paint.

61) Paint the toilet compartment outer walls to match the interior colour of you vehicle.

62) Fix the seats and toilet cubicle to the floor as required following the seating plans in Drawing 1. Keep in mind that you will need to be able to fit the bodies over the seats and toilet details once they are in place, so don't fit them too close to the edge of the floor - test fit first!

FINAL ASSEMBLY

63) (Both Cars) Find the windscreens you put in a safe place some time ago and fit using small amounts of solvent. Alternatively, if you have some RC Modellers glue to hand, dilute a small amount with water and apply from the inside with a small brush to the edge of the glazing allowing capillary action to draw the liquid into the joint.

64) (Both Cars) Before fitting the toilet window, gently rub the inside face with 1200 grit abrasive paper to create a frosted appearance. Fit all windows in a similar manner to the windscreens, i.e. not too much solvent in any single application, or RC Modellers glue as mentioned previously.

65) (Both Cars) Fit the control desks on to the desk supports with two part epoxy.

Note: Since developing the kit and writing these instructions we have become unsure whether the windows in the baggage area actually had security bars. Unless you are absolutely certain they were fitted, it is probably better not to fit them. However, for those that wish to fit security bars follow step 66.

66) (DMBS) Cut the etched security bars from the frets and form to shape. In order to keep the bars quite close to the glass without actually touching it, form the folds as shown right (looking side on). You will notice there are two and three bar etches for the security bars (E5 & E4), the two bar types fit behind the door windows and the three bar types fit the body windows. Fix in place by applying a bead of glue above and below the window glazing and then gently press the folded 'peaks' into the glue. The bars are aligned centrally in the window openings. Note: there are no security bars fitted to windows on the corridor side of the car.



***TIP - RC MODELLERS glue is ideal for fixing the security bars in place.*

67) (Both Cars) Check the fit of the buffers in the stocks once again for a sliding fit, adjust as necessary. Fit the buffers into the stocks (don't forget the springs!) and secure in position by supergluing the retaining ring over the buffer shank protruding through the back of the bufferbeam. The ring should be level with the rear of the buffer shank. Do not be too extravagant with the superglue as it is easy to end up with solid buffers. Also fit the couplings. If you didn't fit the vac pipes and air horns earlier, now is the time to do so. At the time of writing the MU sockets, etc. are not finished so follow the instructions appropriate to their fitment that will be supplied separately with them.

68) (Both Cars) Fit the cab partitions in place (you may wish to install a driver in one end at this stage) and all other internal partitions making sure they stand vertical. The partitions can be glued to the underside of the stretchers installed in line with the passenger doors.

69) (Both Cars) Assemble bodies on to appropriate floors and secure in place.

70) (Both Cars) Mount the bogies and ensure they are free to rotate. The speedo drives can be connected to the solebar units using the outer sheathing from thin electrical signal wire. Do not make the link too short as it will restrict bogie movement, however too long and it may snag on track side components. Start with about 35mm and work back from there until it looks right.

***NOTE - The sheathing used on the demo models is from 10/0.1mm multi-strand wire*

71) (Both Cars) Bend the wiper 'blades' (E1) 90° to the arms so that they present a blade edge to the windscreen ensuring you create two left and two right handed wipers. Solder a piece of 0.4mm wire through the mounting holes in the arms, paint black and fix into the holes previously drilled above the upper edges of the windscreen beading. The wipers are intended to be in the parked positions, which is up against the outer edges of the windscreens. See **Craven end 2.jpeg**.

72) (Both Cars) Fit all door and grab handles. It should also be noted the guard's door has a special etched cranked door handle found on the fret with the hinges and also on the CI. 105 Extras etch)

73) Fix the corridor connection to the rear of one car - only one corridor connection is supplied as two restricts flexibility when the cars are coupled together.

We hope you have enjoyed building this kit and welcome your comments.

SHAWN KAY 2010

DRAWING1

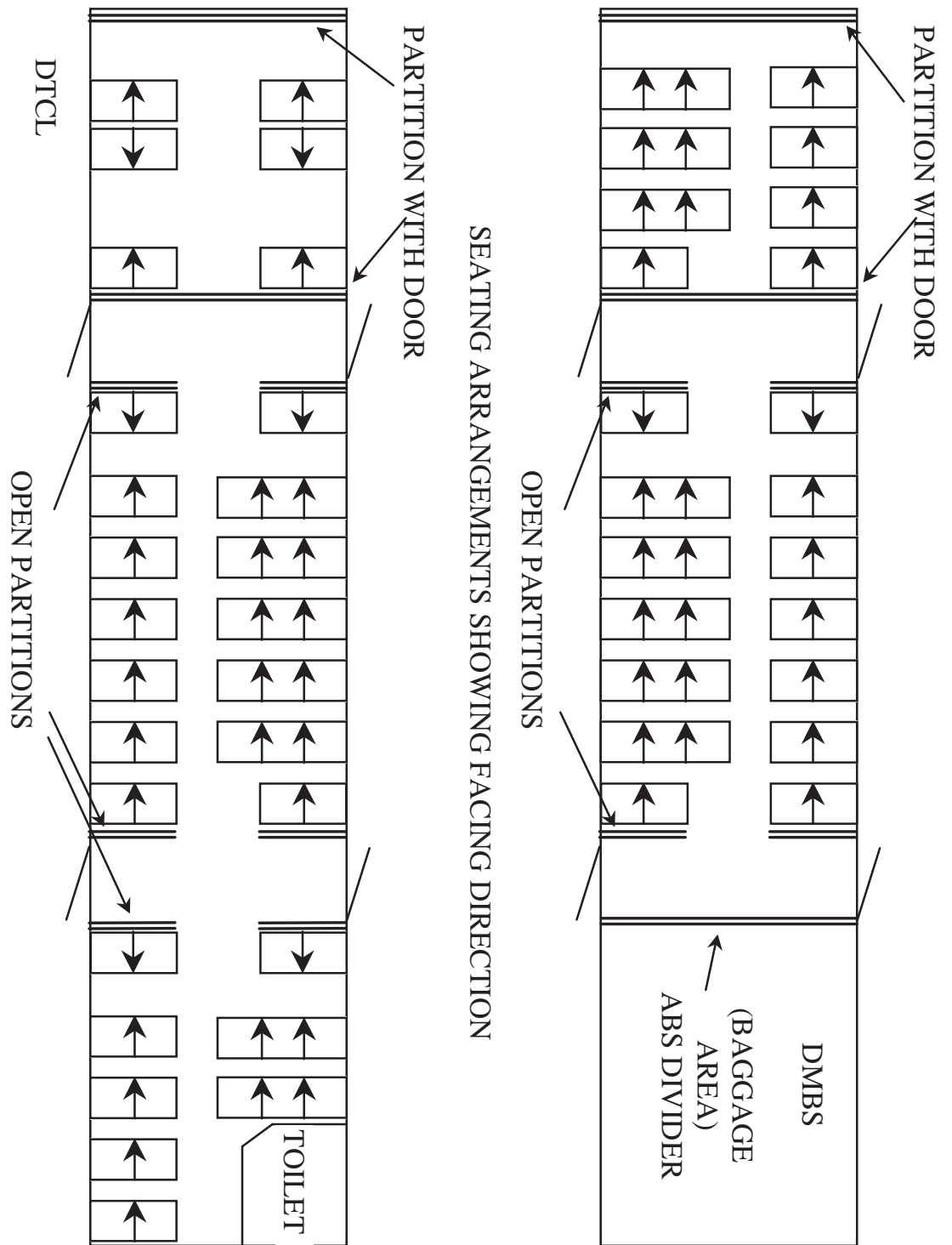

DRAWING2

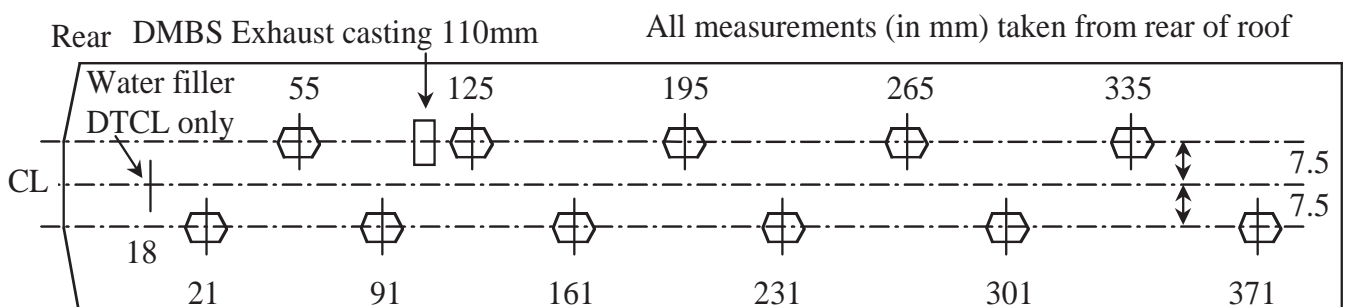

DMBS (POWER CAR) UNDERFRAME DETAILS LAYOUT

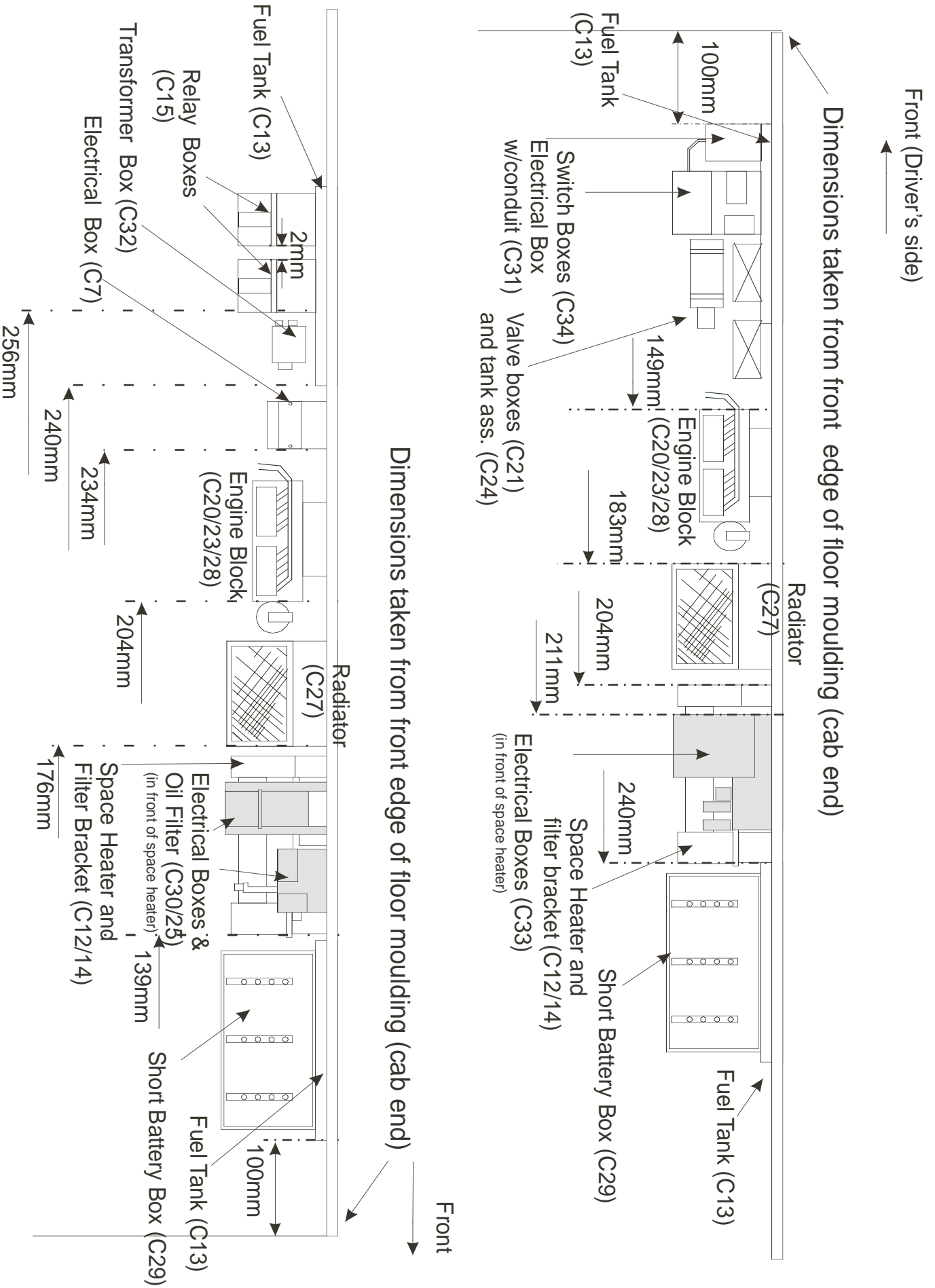

DTCL (TRAILER CAR) UNDERFRAME DETAILS LAYOUT

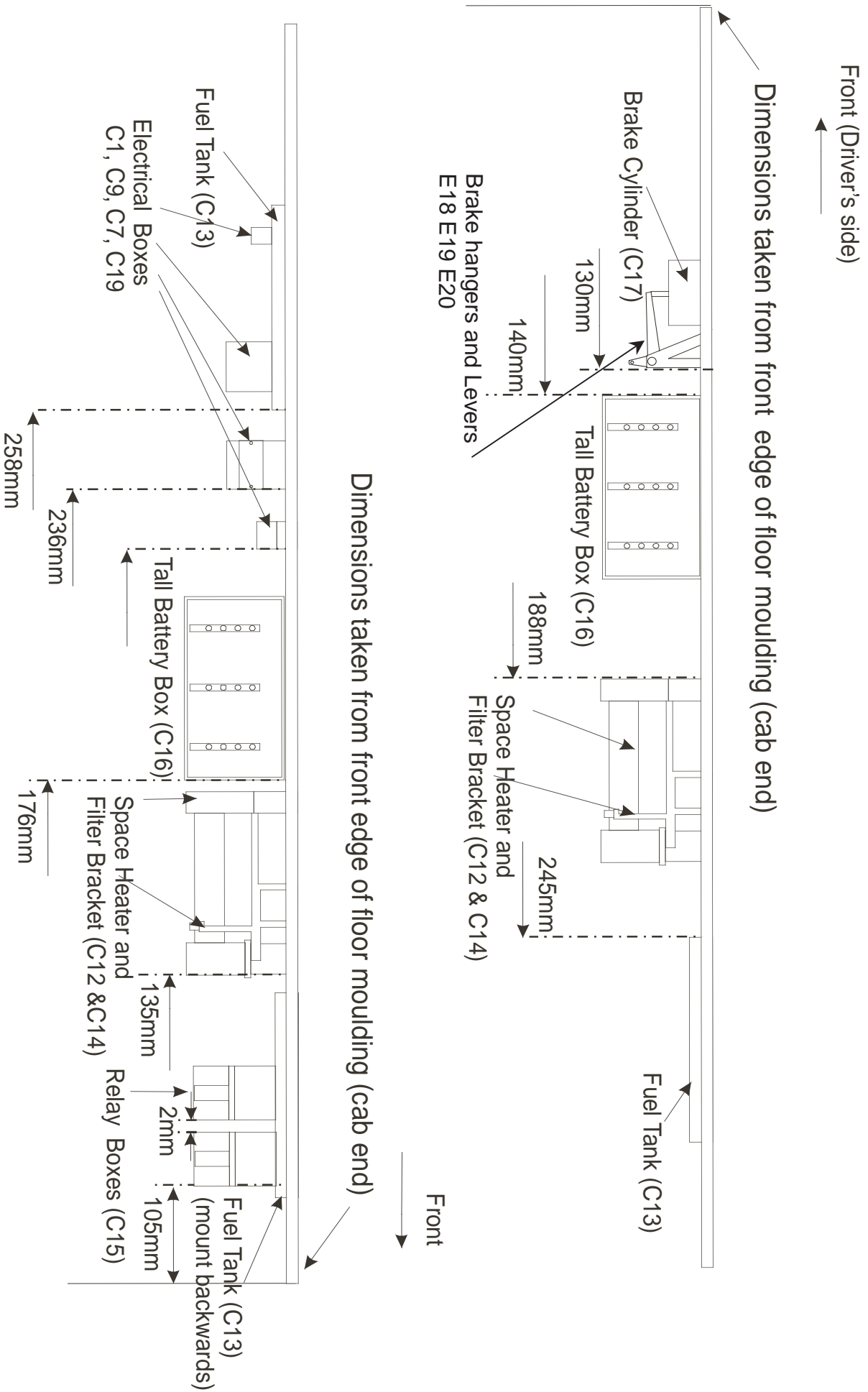

DMBS CASTINGS

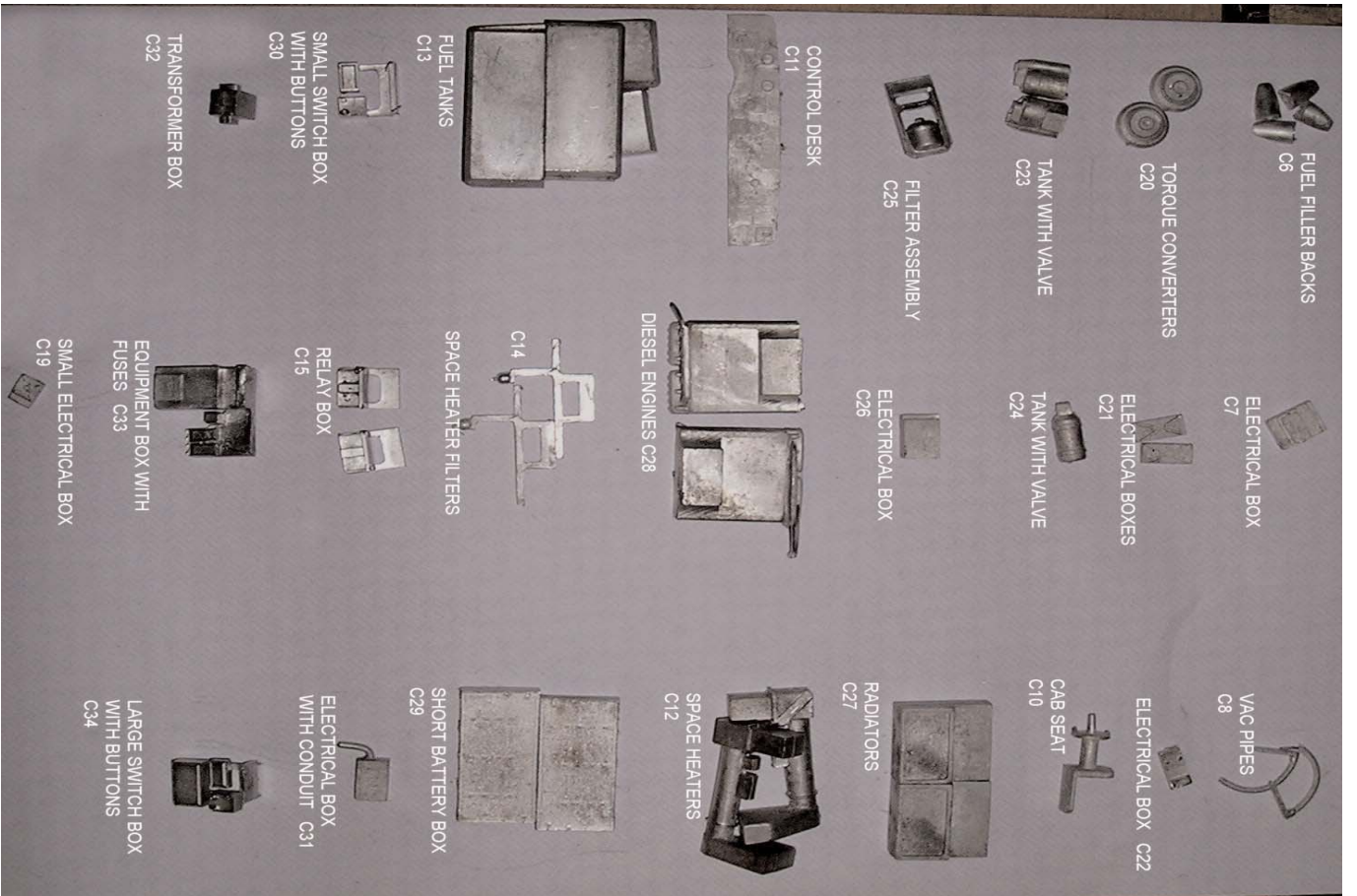

DTCL CASTINGS

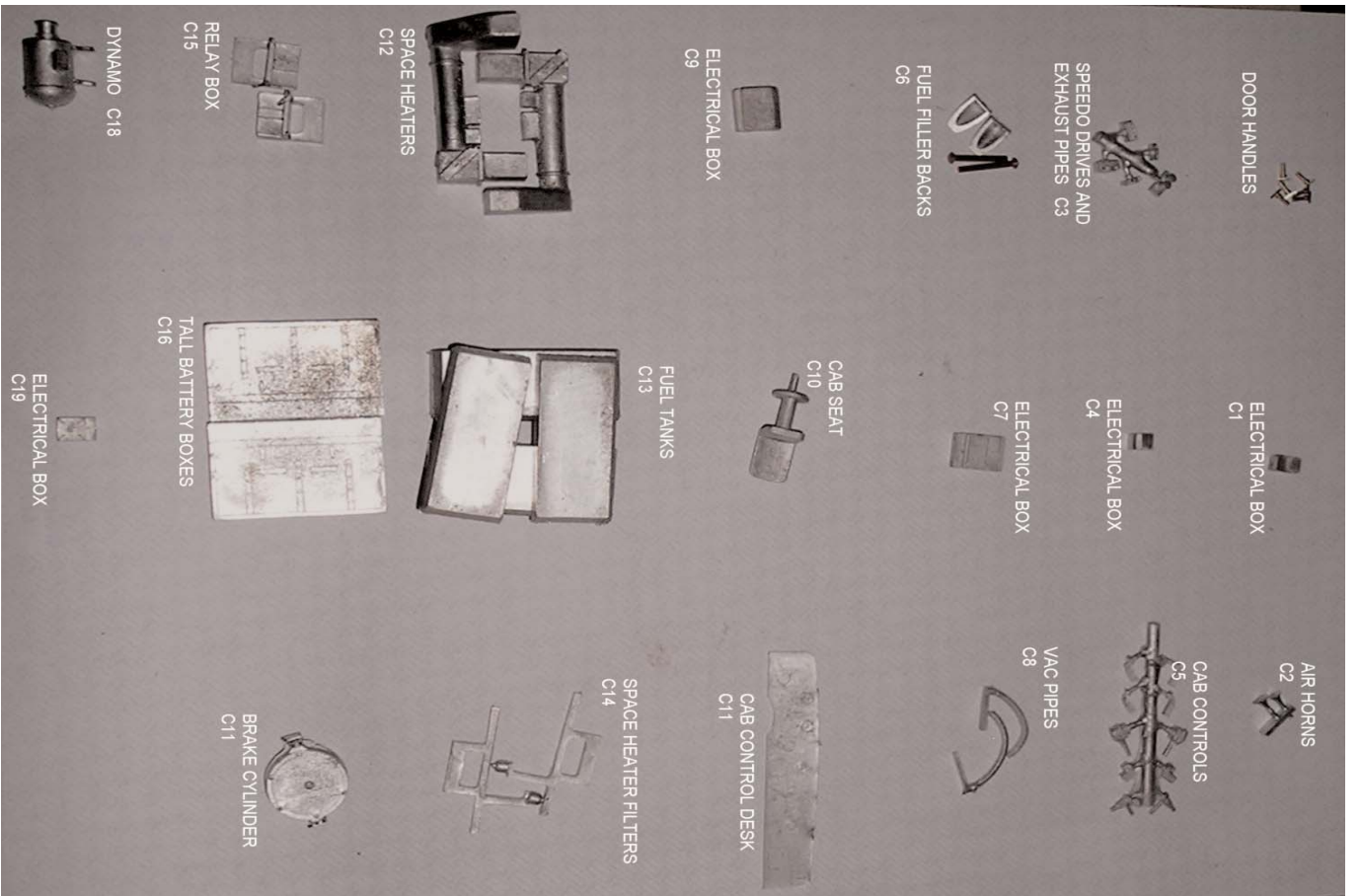

ETCHED
PARTS

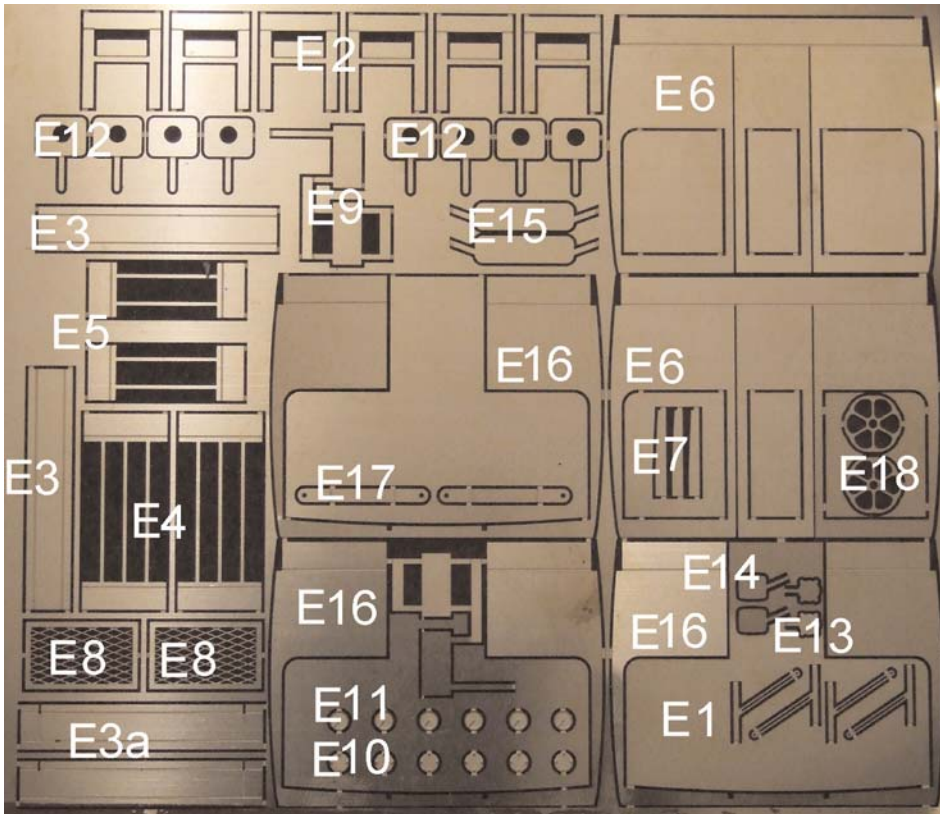

Key:

- | | |
|---|---|
| E1) WINDSCREEN WIPERS | E2) BOGIE STEP SUPPORTS |
| E3) BOGIE FRONT | E3a) BOGIE WITH GUARD IRON CUTOUTS |
| E4) WINDOW BARS | E5) DOOR WINDOW BARS |
| E6) CAB PARTITION | E7) GUARD IRONS |
| E8) RADIATOR GRILLE | E9) CASTINGS SUPPORT (FOR CASTINGS 14 & 18) |
| E10) FUEL TANK PATCH | E11) FUEL TANK GAUGE |
| E12) LAMP IRON MOUNTS | |
| E13) SPEEDO RECEIVER BACKING (FOR SMALL CASTING 6) | |
| E14) SPEEDO SENDER BACKING (USE WITH LARGE CASTING 6) | |
| E15) DESTINATION PANEL | E16) PASSENGER COMPARTMENT DIVIDERS |
| E17) GENERATOR MOUNTING | E18) BRAKE WHEELS FOR CONTROL DESK |

(ON EXTRAS ETCH)

- | | |
|--|---------------------------|
| E18) BRAKE SHAFT HANGER (SORRY! DUPLICATE NUMBER) | |
| E19) BRAKE LEVERS (LONG) | E20) BRAKE LEVERS (SHORT) |
| E21) SIDE BLANKING PLATE (DRIVER'S SIDE) | |
| E22) SIDE BLANKING PLATE (SECOND MAN SIDE) | |
| E23) GUARD DOOR HANDLE | E24) BAGGAGE DOOR HANDLE |



CONTROL DESK DETAILS

